



Technical Manual For FT Battery

TECHNICAL FEATURES

WBDP battery FT (Front Terminals) series Batteries have been specially designed for use in telecom systems. The Front Terminal batteries are suitable for 19",23",and ETSI racking, give users the benefit of increased energy density. With all electrical connections at the front, installation and inspection are simpler and quicker. Designed floating service life at 20°C/68°F is 10~12 years.

Sealed Construction

WBDP's unique construction and sealing technique guarantees that no electrolyte leakage can occur from the terminals or case of any WBDP battery. This feature insures safe and efficient operation of WBDP batteries in any position. WBDP batteries are classified as "Non-Spillable" and will meet all requirements of the International Air Transport Association. (I.A.T.A Dangerous Goods Regulation).

Long Service Life, Float or Cyclic

The **WBDP** VRLA battery has a long life in float or cyclic service. Depending on the average depth of discharge, over 500 cycles (50-70%D.O.D) can be expected from **WBDP** VRLA batteries. The expected service life of **WBDP** VRLA batteries used in floating application is typically 10 years.

Maintenance-Free Operation

During the life of **WBDP** batteries, there is no need to check the specific gravity of the electrolyte, or add water. In fact, there is no provision for such maintenance functions to be carried out.

Low Self Discharge

Because of the use of Lead Calcium grids alloy, **WBDP** VRLA battery can be stored for long periods of time without recharge.

High Recovery Capability

WBDP battery has excellent recharging capability, even after very deep discharge.

Heavy Duty Grids

The heavy-duty lead calcium-alloy grids in **WBDP** batteries provide an extra margin of performance and service life in both float and cyclic applications, even in conditions of deep discharge.

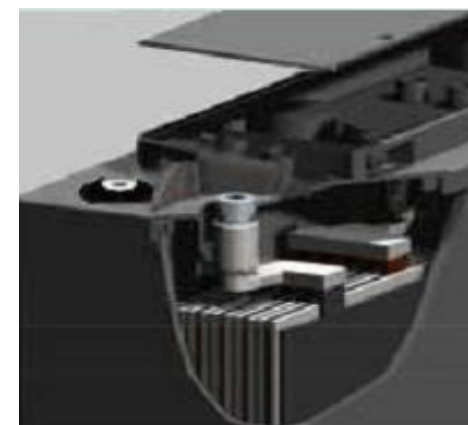



Operating Temperature Range

WBDP batteries can be used over a broad range of ambient temperatures, allowing considerable flexibility in system design and location.

APPLICATION FIELDS (mainly used in the area of communication)



Solar Power Devices&Control Equipment



Communication Equipment



Cable Television



UPS Generator Starting

BATTERY CHARGING

Correct battery charging ensures the maximum possible working life for the battery. There are four major methods of charging:

- Constant Voltage Charging.
- Constant Current Charging.
- Two Stage Constant Voltage Charging.
- Taper Current Charging.

Constant Voltage Charging:

This is the recommended method of charging for VRLA batteries. It is necessary to closely control the actual voltage to ensure that it is within the limits advised.

Float Service: 2.25-2.30 Vpc at 25°C .

Cycle Service: 2.40-2.45 Vpc at 25°C

WBDP suggests that the initial current be set within 0.2C Amps. Figure 1 shows one example of a constant voltage charging.

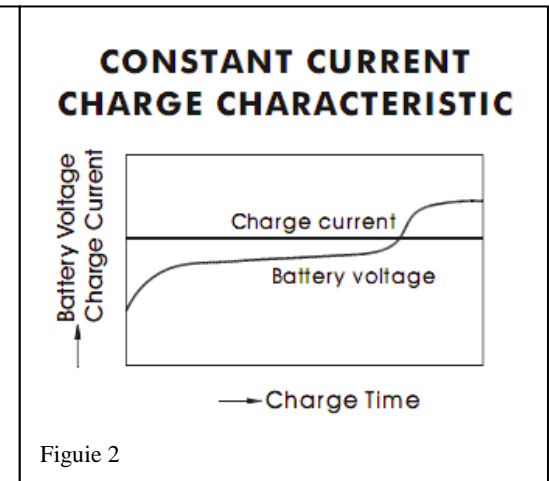
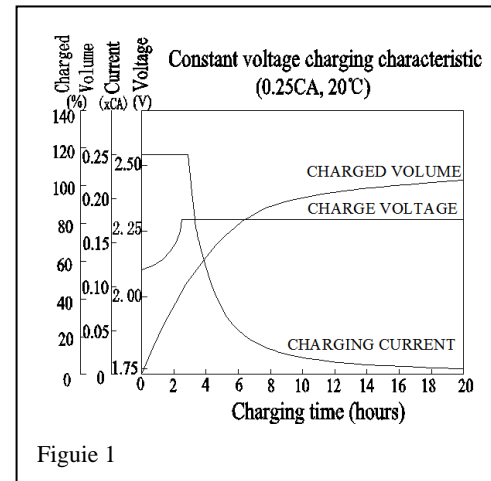

Constant Current Charging

This method of charging is generally not recommended for VRLA batteries, but is an effective method for charging a number of series connected batteries at the same time. It is necessary to understand that if the batteries are not removed from the charger after reaching a state of full charge, considerable damage will occur to the batteries due to overcharging. Figure 2 shows the characteristics of a WBDP battery under constant current charging conditions.

Two Stage Constant Voltage Charging

Two stage of constant voltage charging is a recommended method for charging valve regulated lead acid battery in a short period of time and then maintain them in a fully charged float or standby condition. Figure 3 illustrates the characteristics of a two stages constant voltage charging.

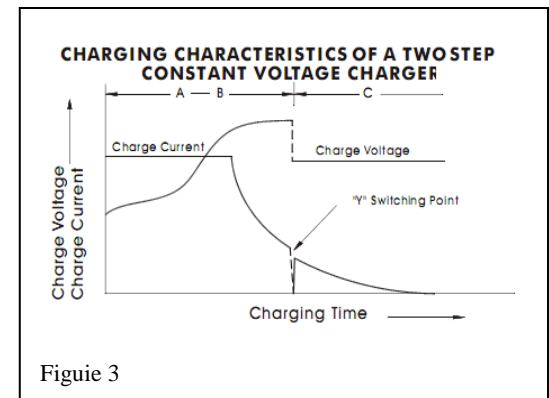



Taper Current Charging

This method is not recommended for VRLA batteries for it has somewhat harsh on battery performance. However, because of the simplicity of the charger circuit and its low cost, taper current charging is often used to charge a number of series connected batteries that are subject to cyclic use. If this method is to be used, it is suggested that the **WBDP** technical department should be contacted.

Effect of Temperature on Charging Voltage

As temperature rises, electrochemical activity in a battery increases. Similarly, as temperature falls, electrochemical activity decreases. Therefore, conversely, as temperature rises, charging voltage should be reduced to prevent overcharge and increased as temperature falls to avoid undercharge. In general, to assure optimum service life, use of a temperature compensated charger is recommended. The recommended compensation factor for **FT** batteries is $-3\text{mV}/^\circ\text{C}/\text{Cell}$ (standby use) and $-5\text{mV}/^\circ\text{C}/\text{Cell}$ (cyclic use). The standard center point for temperature compensation is 25°C . Figure 4 shows the relationship between temperatures and charging voltages in both cyclic and standby applications.

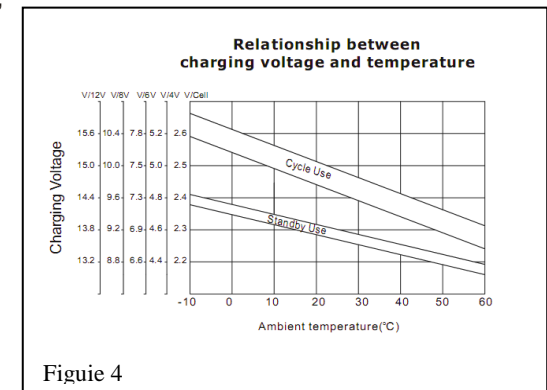

Effect of Voltage on Battery Gassing

Although the batteries are of the recombination type and the amount of gassing at normal operating voltages and temperature are negligible, if the charging voltage is increased, gassing will occur despite the recombination design of the product. Gassing does not normally occur while the battery is operating under float conditions and normal constant voltage recharge of 2.25-2.30 Vpc at 25°C . Very little gassing occurs when the battery is recharged under normal cycling recharge procedures. However, it can be seen on the accompanying graph the higher voltages that this especially under conditions of constant current charging will substantially increase the volume of gas.

DISCHARGE CHARACTERISTIC

The discharge capacity of a lead acid battery varies and is dependent on the discharge current. **WBDP** VRLA battery capacity is measured at the 10-hour rate. The standard industry practice to determine the nominal capacity of a valve regulated lead acid battery is to discharge the battery under test at its 10-Hour rate to a final voltage of 1.8 volts per cell. The curves in Figure 5 show the different currents that can be drawn at various discharge capacity rates at an ambient temperature of 25°C . The rated nominal capacity of a battery is reduced when it is discharged at a value of current that exceeds its 10-Hour discharge rate. This should be taken into consideration when a battery is being selected for a particular application.

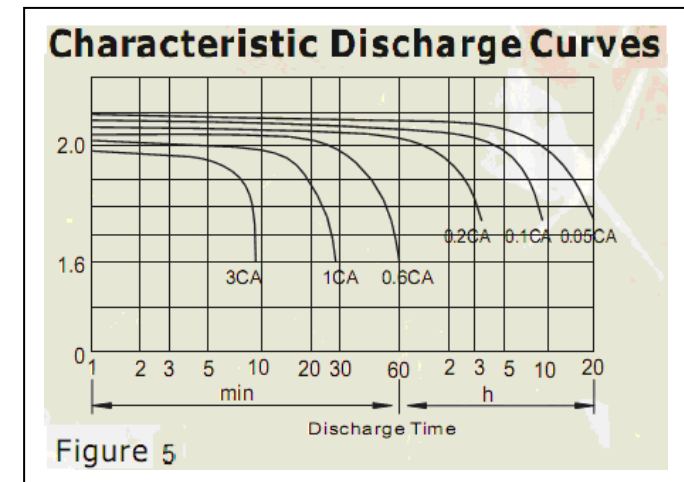



Technical Terms

1. Battery capacity for FT VRLA batteries by accepted convention worldwide is described in "AMPERE HOUR" at the 10-hour rate C when discharged at 25°C. i.e. a FT12500 is 50 Ah at "C" that means the battery will deliver 5 amps current for 10 hours to a cut off voltage of 1.8 volts per cell (10.8 volts per battery).
2. Battery cut-off voltage is the volts per cell to which a battery may be discharged safely to maximize battery life. This data is specified according to the actual discharge load and run time. As a rule of thumb, high amp loads and short run times will tolerate a lower cut off voltage (eg. 3C at 1.3V/C), whereas a low amps long run time discharge will require a higher cut-off voltage (eg.0.1C at 1.8V/C).

Self Discharge

The self discharge rate of **WBDP** batteries is approximately 3% per month when stored at an ambient temperature of 25 °C. The self discharge rate will vary as a function of ambient storage temperature. Figure 4 shows the relationship between storage times at various temperatures and the remaining capacity.

Shelf life

In general, when lead acid batteries of any type are stored for extended periods of time, lead sulphate is formed on the negative plates of the batteries. This phenomenon is referred to as "sulphation ". Since the lead sulphate acts as an insulator, it has a direct detrimental effect on charge acceptance. The more advanced the sulphation, the lower the charge acceptance. Table 1 below shows the normal storage time or shelf life at various ambient temperatures.

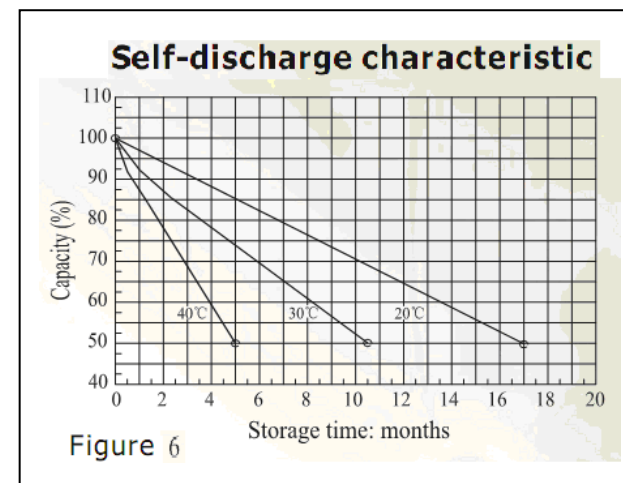

Brief excursions i.e., a few days, at temperatures higher than the ranges recommended above will have no adverse effect on storage time or service life. However, should the higher ambient temperature persist for one month or more, the storage time must be determined by referring to the new ambient temperature. Ideally **WBDP** batteries should be stored in dry, cool conditions.

Table 1 Shelf life at various temperatures

Temperature	Life
Below 20°C (68°F)	9 months
21°C (70°F) to 30°C (86°F)	6 months
31°C (88°F) to 40°C (104°F)	3 months
41°C (106°F) to 50°C (122°F)	1.5 months



RECHARGING STORED BATTERIES

In general, to optimize performance and service life, it is recommended that **WBDP** batteries which are to be stored for extended periods of time be given a supplementary charge, commonly referred to as a "top charge", periodically. Since any battery loses capacity through self discharge, it is recommended that, prior to putting the battery into service, a process called "top charging" be applied to any battery which has been stored for a long period of time.

Excluding conditions in which storage temperatures have been abnormally high, top charging is recommended within the following parameters (Table 2):

Battery Age	Top Charging Recommendations
Within 6 months after manufacture	4 to 6 hours at constant current of 0.1C Amps or 15 to 20 hours at constant voltage of 2.45Vpc
Within 12 months after manufacture	8-10 hours at constant current of 0.1C Amps or 20-24 hours at constant voltage of 2.45Vpc

In order to successfully top charge a battery stored for more than 12 months, the open circuit voltage must be checked to ensure that it is higher than 2.0 volts per cell.

Therefore ALWAYS check the open circuit voltage FIRST. If the open circuit voltage of the battery is 2.0 Vpc or lower, please refer to us prior to attempting to "Top Charge".

Effect of Temperature on Battery Capacity

The nominal battery capacity is based on the temperature of 25°C. Above this temperature, the capacity increases marginally but it must be noted that the working battery should be kept within the temperature design limitations of the product.

Below 25°C, the capacity decreases. This decrease in capacity becomes more prominent at temperatures below 0°C and in heavy discharge rates. Figure 7 below illustrates the situation and the decrease in capacity with the decrease in operating temperature. Temperature must be taken into capacity design calculations in applications where the operating temperature of the system is below 25°C

STANDARDS

You can expect our batteries meet with the standards JIS, DIN, IEC & BS6290-4. We have obtained ISO9001 certification. We have obtained UL and CE approval for all types of batteries. All these render our batteries to be compatible with requirements of world-level equipments.

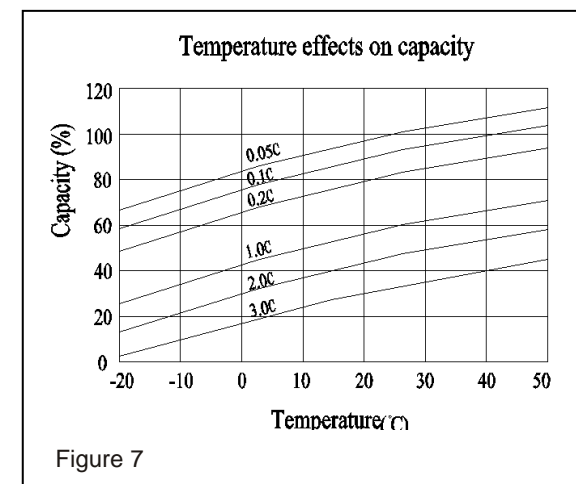



MAINTENANCE

- Check the tightening of connections.
- Every month, it is recommended that the total voltage at the battery terminals be measured. It should be 2.25-2.30Vpc at a temperature of 25°C. Once each year, it is recommended that the voltage of each cell in the battery should be read off.
- A difference of plus or minus 2.0% between these individual voltages and the average voltage may be observed. This is due to the gas- recombination process.
- A check on capacity (independent operation on load) can be performed once or twice per year.

Safety: When carrying out any work on the battery, the applicable safety standards should be followed.

Note: it is recommended that a battery log be maintained, and that records should be kept of the total voltage measurements, any mains failures, major battery discharges (current and time) etc.

The main factors causing reduction in the life expectancy of **WBDP FT** Series cells:

- Deep discharges
- Poor regulation on the float voltage
- Cycling or micro- cycling
- Poor quality (smoothing) of the charging current
- High ambient temperature.

INSTALLATION OF THE BATTERY

General recommendations

- Do not wear clothing of synthetic material, to avoid the generation of static potentials.
- Use insulated tools.
- Consult the drawing for the correct position of the cell poles (positive=red colour, negative = black colour).
- Before attaching the inter-cell flexible cables, check that all terminals are in the correct position.



- The battery cells are connected in series, which is with a positive pole connected to a negative pole.
- Use only a damp cotton cloth for cleaning purposes.
- There is no technical reason for limiting the number of strings but for practical installation reasons, it is recommended not allowed to exceed 3 strings in parallel especially if the battery is used in high discharge rates (backup time less than 15 mins)

OTHER CAUTIONS

- (1) When cleaning the batteries, use soft cloth only. Use of organic solvents such as gasoline or thinner, and application or adherence of oil to the batteries must be avoided. Do not clean the batteries using dirty or oily cloth. Also contact with soft polyvinyl chloride or the like must be avoided.
 - (2) Batteries may generate inflammable gas in some cases. Do not expose them to flame or excess heat. Do not short batteries.
 - (3) Do not attempt to disassemble the batteries. Avoid contact with sulfuric acid leaking from broken batteries. If acid gets into contact with clothes, rinse the area generously with water. If acid gets into contact with your skin or eyes, generously wash the affected area with clean water, and consult a physician immediately.
 - (4) Batteries explode if put into the fire. Never dispose of batteries in the fire.
 - (5) Mixed usage of batteries differing in capacity, type, manufacturer or history of use (charge/discharge operation) must be AVOIDED for this may damage the batteries and the equipment due to the difference in characteristic values.
 - (6) While our batteries are exceptionally dependable, we do not recommend use in life support medical applications unless there is an alternate battery or back-up power supply.
 - (7) Acid leakage and unusual appearance must be avoided before switching on, noting open circuit voltage.
 - (8) There must be appointed man operating for 24 hs after switching on to solving potential problems in time, noting voltage and current.
 - (9) When the batteries come to their end of life, discharge duration time becomes shorter. Finally, batteries lose their available capacity by internal short-circuit and/or dry out of electrolyte.
- Therefore, please consider the design of the charger for the battery with some care regarding above battery damage modes, such as short-circuit protection for out put.